

# HARDWARE SETUP GUIDE

## 1 SITE PREPARATION *Before you begin:*

### Unpacking the appliance

- Verify that the ship kit includes a power cord, the screws, cone washers and cage nuts (shown below) that you will need to install the appliance in your rack, along with the 4- and/or 2-post rack rail bracket assemblies.

#### Screws, cone washers and cage nuts

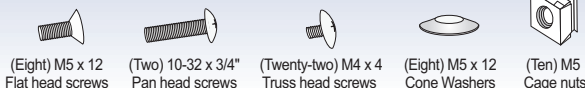

### The Appliance chassis rail assembly consists of 2 sections:

1. A set of long fixed chassis rails that attach directly to the rack(s).
2. A set of inner fixed chassis rails that attach to the appliance (these must be removed from the set of long, outer fixed chassis rails).

**Note:** See **2a** or **2b - Step 1** on the reverse side of this document for rack assemblies.

### The 4-post rack assembly consists of:

1. A set of long, fixed rack brackets (**A**).
2. A set of short, fixed rack brackets (**B**).

**Note:** See **2a** on the reverse side of this document for rack assemblies.

### The 2-post rack assembly consists of:

1. A set of long, fixed rack brackets (**A**).
2. Two sets of short rack brackets (**B** and **C**). Set (**C**) has threaded holes (for placement in the in the front) to allow the appliance to be secured in the rack.

**Note:** See **2b** on the reverse side of this document for rack assemblies **A, B** and **C**.

### Setup location

- Choose a setup location with proper temperature control and adequate floor loading capacity for the current installation and for future growth.
- Install near appropriate AC outlets, and Ethernet hubs or individual jacks.
- Leave enough clearance, 25 inches in the front, and 30 inches in the back of the rack to enable you to access appliance components and allow for sufficient airflow.

### Rack and appliance precautions

- **ALL RACKS MUST BE MOUNTED SECURELY.** Ensure that all leveling jacks or stabilizers are properly attached to the rack. If installing multiple appliances in a rack, make sure the overall loading for each branch circuit does not exceed the rated capacity.
- Do not slide more than one appliance out from the rack at a time. Extending more than one appliance at a time may result in the rack becoming unstable. Install your appliance in the lower part of the rack because of its weight and also for ease in accessing appliance components.
- Allow the hot plug disk drives to spin down before touching them.
- Always keep the rack's front door and all panels and components on the appliances closed when not servicing to maintain proper cooling.

### CAUTION

*This appliance is intended for installation in restricted areas only. Initial setup and maintenance should be performed by qualified personnel.*

### CAUTION

*Required operating conditions for the appliance are -  
Temperature:  
10 to 35°C (50 to 95°F)  
Relative Humidity:  
non-condensing:  
8 to 90%.*

### CAUTION

*Installation or operation of appliances stacked on a desktop table is not supported.*

#### AE1470sa Ratings:

V: 100 - 240  
Hz: 60/50  
A: 5.0

*Use the hardware supplied with your specific rack if different from the hardware supplied in this kit.*

### CAUTION

*To prevent the unit from overheating, never install the appliance in an enclosed rack or room that is not properly ventilated or cooled. For proper airflow, keep the front and back sides of the appliance clear of obstructions and away from the exhaust of other equipment.*

### CAUTION

*Do not use mats designed to decrease static electrical discharge as protection from electrical shock. Only use mats that have been specifically designed as electrical insulators.*

### CAUTION

*Power down the appliance following the operating system's proper power down procedure from the front panel. It is also recommended that the power cord be unplugged before servicing.*

### CAUTION

*Failure to properly ground the appliance, either by circumventing the 3-wire grounding-type plug or by using a power outlet that is improperly grounded, can create a potentially hazardous electrical situation.*

### CAUTION

*Electrostatic Discharge (ESD) precautions are required before handling the appliance. Wear a wrist strap with an appropriate ground connection.*

### CAUTION

*There is a danger of explosion if the battery is replaced incorrectly. Replace only with the same or equivalent type recommended by the manufacturer. Dispose of used batteries according to the battery manufacturer's instructions. Contact technical support if you need to replace a battery to ensure proper replacement.*

### FCC Notice

This device complies with part 15 of the FCC Rules. Operation is subject to the following two conditions: (1) This device may not cause harmful interference, and (2) this device must accept any interference received, including interference that may cause undesired operation.

No Telecommunications Network Voltage (TNV)-connected PCBs shall be installed.

This class A digital apparatus complies with Canadian ICES-003. Cet appareil numérique de la classe A est conforme à la norme NMB-003 du Canada.

### CE Mark Warning

This is a Class A product. In a domestic environment, this product may cause radio interference, in which case the user may be required to take adequate measures.

### Environmental Warning

Perchlorate Material - special handling may apply. See [www.dtsc.ca.gov/hazardouswaste/perchlorate](http://www.dtsc.ca.gov/hazardouswaste/perchlorate). This notice is required by California Code of Regulations, Title 22, Division 4.5, Chapter 33: Best Management Practices for Perchlorate Materials. This product/part includes a battery that contains Perchlorate material.

### VCCI Warning

This is a product of VCCI Class A Compliance.

#### 注意

この装置は、情報処理装置等電波障害自主規制協議会 (VCCI) の基準に基づく第一種情報技術装置です。この装置を家庭環境で使用すると電波妨害を引き起こすことがあります。この場合には使用者が適切な対策を講ずるよう要求されることがあります。

©2008 All rights reserved.



P/N: 509-9255-00



REV: 0A

**NOTE:** The following installation procedures for **2a**, 4-post rack and **2b**, 2-post rack are for use with the rails and hardware provided in your ship kit. If different style rails are being used, or if your rack requires different hardware, refer to the instructions provided with your rail's or rack's ship kit.

## 2a 4-Post Rack Installation

Unpack the appliance and locate the mounting hardware

### Step 1 (4-post rack)

- Remove the inner fixed chassis rails from the outer fixed chassis rails. Pull each one out as far as possible. Depress the locking tab to pull the inner rail completely out. Put these rails aside for later installation on the appliance.



### Step 2 (4-post rack)

- Attach the long (A) and short (B) brackets to the outer fixed chassis rails as shown, using the shorter ones in the front and the longer ones in the rear. Leave approximately one inch of space between the front end of the shorter bracket and the outer fixed chassis rail in the front. The two vertical holes in the front brackets align with the threaded holes in the front of the rails. Secure with four M4 x 4 screws, two in the front and two in the rear on each side. Hole locations vary depending upon your rack.

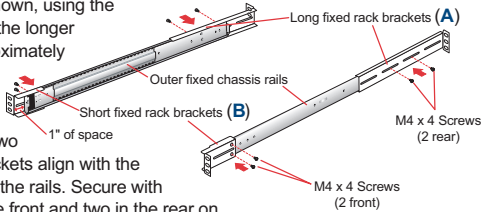

### Step 3 (4-post rack)

- Insert a cage nut into each of the square holes in the rack you will be using as shown (3 in the front and two in the rear). They click into place. Attach the rack / rail assemblies to the rack using two M5 x 12 flat head screws and cone washers in the front and back. **The convex side of the cone washers face toward the rack.** Make sure the rack / rail assemblies and screws are aligned in the rack not only in the front and back, but are level in height on the left and right sides for proper alignment for appliance installation.

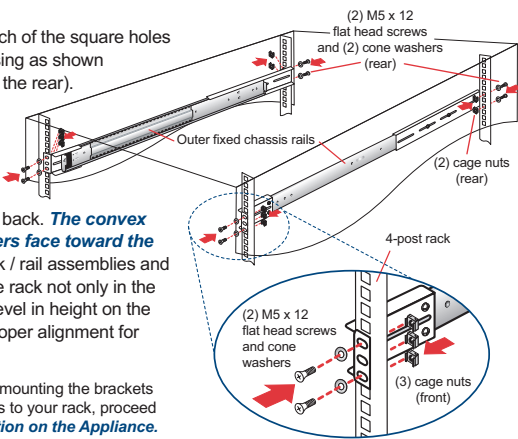

Once you have completed mounting the brackets and outer fixed chassis rails to your rack, proceed to **Section 3, Rail Installation on the Appliance.**

## 2b 2-Post Rack Installation

Unpack the appliance and locate the mounting hardware

### Step 1 (2-post rack)

- Remove the inner fixed chassis rails from the outer fixed chassis rails. Pull each one out as far as possible. Depress the locking tab to pull the inner rail completely out. Put these rails aside for later installation on the appliance.

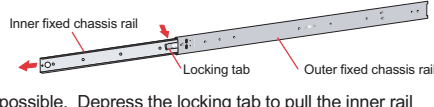

### Step 2 (2-post rack)

- Attach the long fixed (A) and the small (B) rack brackets to the telco style rack. Mount the short brackets in the front, and the longer brackets in the back using two M5 x 12 flat head screws and cone washers for each bracket as shown using the top and bottom holes. Make sure the brackets and screws are aligned in the rack not only in front and back, but are level in height on the left and right sides for proper alignment to allow accurate appliance installation.

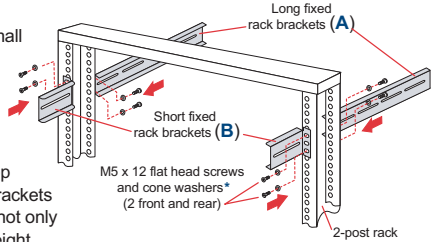

\* Use hardware supplied with your rack if different than supplied.

### Step 3 (2-post rack)

- Slide each of the outer fixed chassis rails into the left and right fixed brackets and loosely secure with four M4 x 4 truss head screws on each side (shown with red dotted lines). Leave enough of the outer fixed rails extended in the front to attach fixed rack brackets (C) to the rack rails using two M4 x 4 truss head screws on each side (shown with the blue dotted lines). There should be approximately one inch of space between brackets (B) and (C) in the front. Once all screws are in place, tighten each one to secure the outer fixed chassis rails in place.

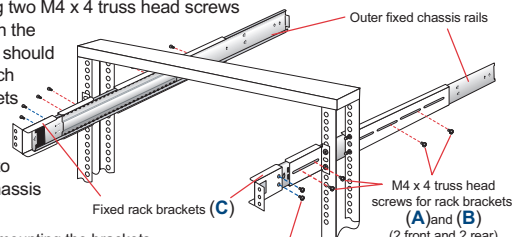

Once you have completed mounting the brackets and outer fixed chassis rails to your rack, proceed to **Section 3, Rail Installation on the Appliance.**

## 3 Rail Installation on the Appliance

Locate the fixed chassis rails that were put aside in Step 1 of Section 2a or b

### Step 1 (both racks)

- Mount the inner fixed chassis rails to each side of the appliance using five M4 x 4 truss head screws on the left and right sides as shown below.

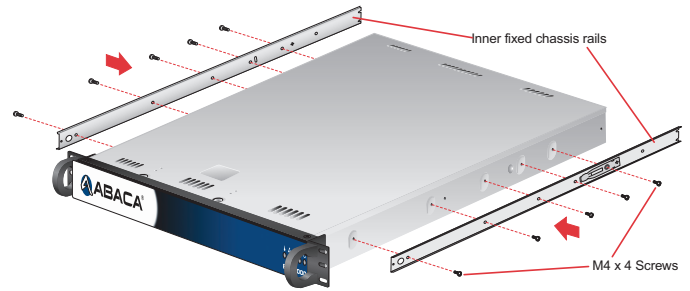

### Step 2 (both racks)

- Align the inner fixed chassis rails on the appliance with the outer fixed chassis rails previously installed the rack. Carefully slide the appliance into these rack rails until you hear the rails click into place. You may need to hold the rack rail slides to insert the appliance properly. Push the appliance all the way back into the rack until it stops. Secure the unit in the rack by inserting and tightening two 10-32 x 3/4" screws on each side.

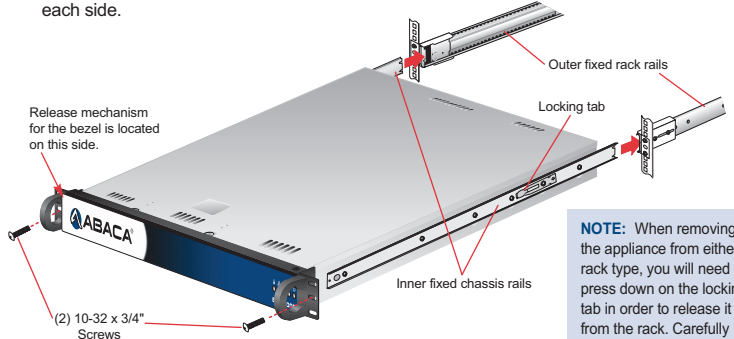

**NOTE:** When removing the appliance from either rack type, you will need to press down on the locking tab in order to release it from the rack. Carefully slide it out supporting the unit on both sides at all times.

## 4 Rear Panel Cable Connections

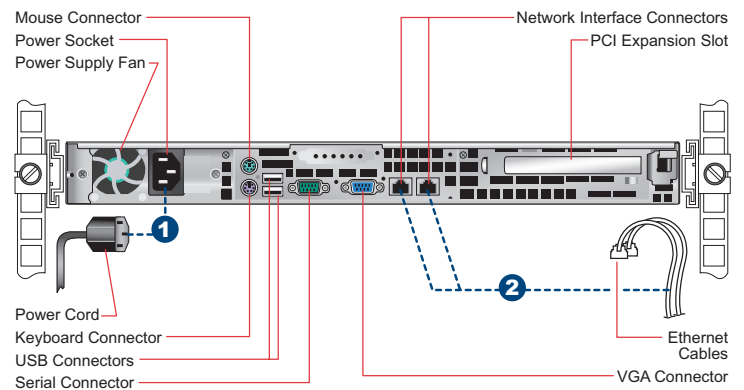

### Cabling the appliance

1. Connect the power cord.
2. Connect the Ethernet cables.
3. Connect other required cables.
4. Turn the appliance on. Remove the front bezel. The power button is the last button on the right on the front of the appliance. Once system has been powered on, replace the bezel.

